

Surname	Centre Number	Candidate Number
Other Names		2



**GCE AS**

B410U20-1



**CHEMISTRY – AS component 2**  
**Energy, Rate and Chemistry of Carbon Compounds**

FRIDAY, 25 MAY 2018 – MORNING

1 hour 30 minutes

For Examiner's use only		
Question	Maximum Mark	Mark Awarded
<b>Section A</b> 1. to 6.	<b>10</b>	
<b>Section B</b> 7.	<b>21</b>	
8.	<b>14</b>	
9.	<b>21</b>	
10.	<b>14</b>	
<b>Total</b>	<b>80</b>	

B410U201  
01

**ADDITIONAL MATERIALS**

In addition to this examination paper, you will need a:

- calculator;
- **Data Booklet** supplied by WJEC.

**INSTRUCTIONS TO CANDIDATES**

Use black ink or black ball-point pen.

Write your name, centre number and candidate number in the spaces at the top of this page.

**Section A** Answer **all** questions in the spaces provided.

**Section B** Answer **all** questions in the spaces provided.

Candidates are advised to allocate their time appropriately between **Section A (10 marks)** and **Section B (70 marks)**.

**INFORMATION FOR CANDIDATES**

The number of marks is given in brackets at the end of each question or part-question.

The maximum mark for this paper is 80.

Your answers must be relevant and must make full use of the information given to be awarded full marks for a question.

The assessment of the quality of extended response (QER) will take place in **Q.7(e)**.

If you run out of space, use the additional page(s) at the back of the booklet, taking care to number the question(s) correctly.

## SECTION A

Examiner  
only

Answer **all** questions in the spaces provided.

1. Ethanol is produced industrially by hydration of ethene. The reaction is typically carried out using a catalyst at 300°C and 70 atm pressure.

Name the catalyst used in this reaction.

[1]

.....

2. But-2-ene can exist as *E*- and *Z*- isomers.

(a) Draw the **skeletal** formula for *Z*-but-2-ene.

[1]

(b) Explain why but-2-ene can form *E*- and *Z*- isomers but but-1-ene cannot.

[2]

.....

.....

.....

.....

.....

3. Explain the meaning of the term heterolytic bond fission.

[1]

.....

.....

4. Name the alkene monomer that can be polymerised to give the following polymer.

[1]

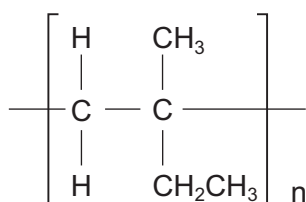

.....

5. Explain how a catalyst speeds up a reaction. [2]

.....

.....

.....

6. The rate of the reaction between calcium carbonate and acid can be found by measuring the loss in mass of the reactants over time.

The graph below shows the results obtained when a large excess of calcium carbonate was added to  $50.0 \text{ cm}^3$  of  $1.00 \text{ mol dm}^{-3}$  hydrochloric acid at room temperature.

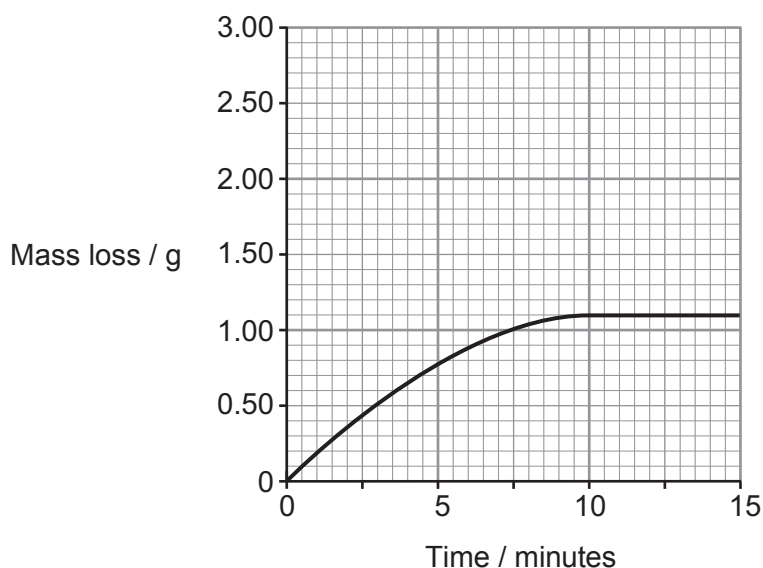

- (a) **On the grid**, sketch the curve that would be obtained if the experiment were repeated at  $60^\circ\text{C}$  with all other conditions being unchanged. Label this curve **A**. [1]
- (b) **On the grid**, sketch the curve that would be obtained if the experiment were repeated using  $2.00 \text{ mol dm}^{-3}$  hydrochloric acid with all other conditions being unchanged. Label this curve **B**. [1]

## SECTION B

Answer **all** questions in the spaces provided.

7. (a) Alkanes are derived from petroleum and many are used as fuels. Some of the compounds found in petroleum contain sulfur.

State and explain **one** reason why sulfur compounds should be removed from fuels before they are used. [2]

.....

.....

.....

- (b) Propane is a constituent of liquefied petroleum gas (LPG). Propane burns in air to form carbon dioxide and water. The equation for the reaction is as follows.

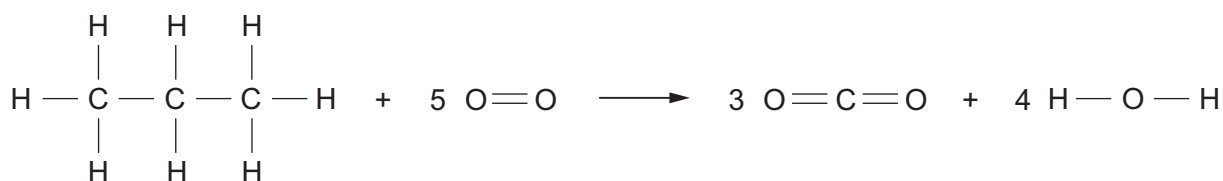

The enthalpy change for the reaction is  $-1690 \text{ kJ mol}^{-1}$ .

Use this and the data given in the table below to calculate the average bond enthalpy for the C—H bond. [3]

Bond	Average bond enthalpy / $\text{kJ mol}^{-1}$
C—C	348
O—H	463
O=O	496
C=O	743

C—H bond enthalpy = .....  $\text{kJ mol}^{-1}$

(c) When methane and chlorine are combined in sunlight a reaction occurs with chloromethane formed as the main organic product.

(i) Name the type of reaction mechanism which occurs in this case. [1]

(ii) Write the mechanism for this reaction to form chloromethane. Include one termination step. [4]

(d) Butane is another common alkane. Two other compounds with a similar molecular mass to butane are ethanoic acid and propan-1-ol.

The boiling temperatures in °C for butane, ethanoic acid and propan-1-ol are

–1, 97 and 118, **but not necessarily in that order.**

Deduce the boiling temperature of **each** compound, giving reasons in support of your conclusions. [3]

- (e) Compounds **A** and **B** are two of butane, ethanoic acid and propan-1-ol.  
Their  $^{13}\text{C}$  NMR spectra and simplified mass spectra are shown below.

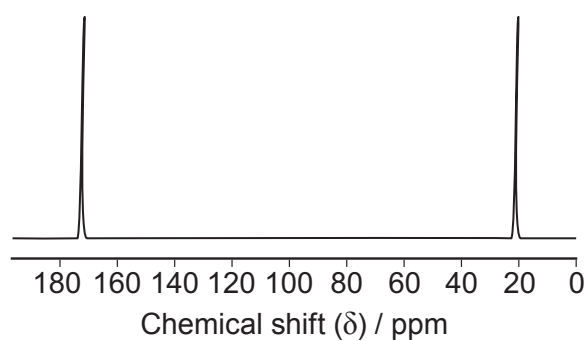
**Compound A** $^{13}\text{C}$  NMR spectrum

Mass spectrum

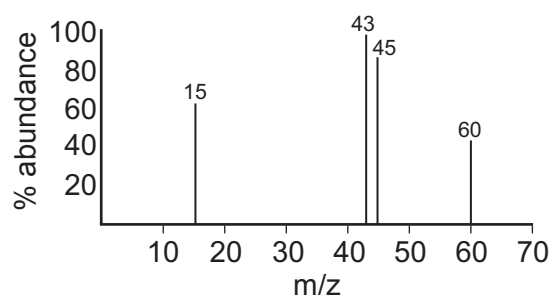
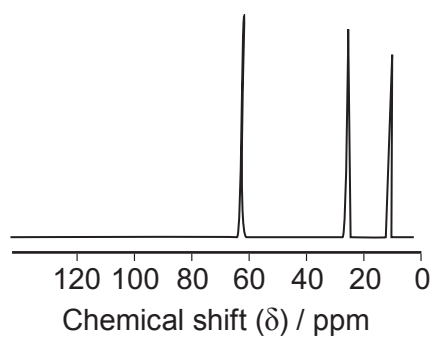
**Compound B** $^{13}\text{C}$  NMR spectrum

Mass spectrum

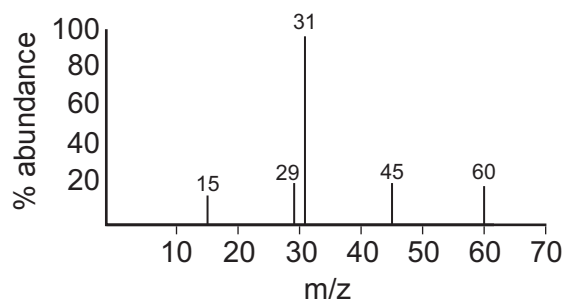

Use the information to identify compounds **A** and **B** clearly explaining your reasoning. Describe the main features that would be seen in the  $^{13}\text{C}$  NMR spectrum and the mass spectrum of the **remaining** compound. [6 QER]

Examiner only

.....  
.....  
.....  
.....  
.....  
.....  
.....  
.....  
.....  
.....  
.....  
.....  
.....  
.....  
.....  
.....  
.....  
.....  
.....  
.....  
.....  
.....  
.....

(f) State and explain how you would expect the infrared spectrum of ethanoic acid to differ from that of propan-1-ol. [2]

.....  
.....  
.....  
.....

21

8. (a) Study the reaction scheme shown below and the other information about compounds **A-E** that follows.

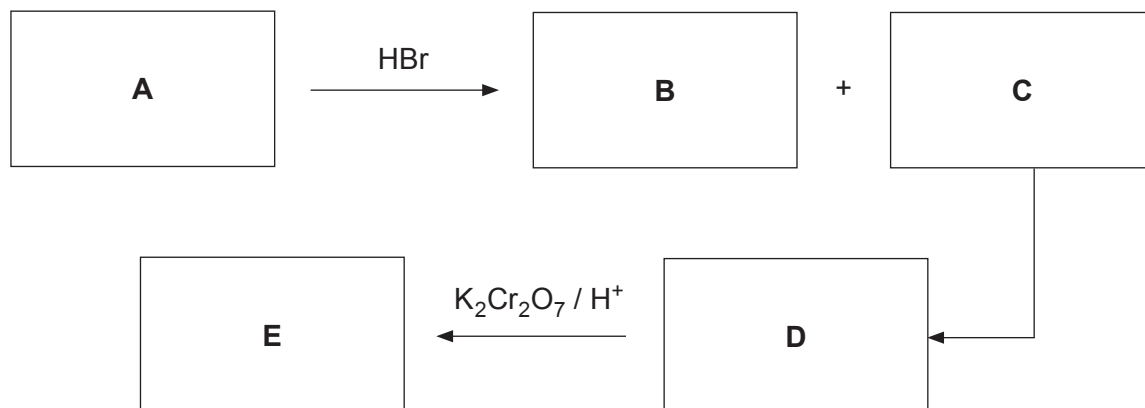

Compound **A** is a straight-chained gaseous hydrocarbon.

Compounds **B** and **C** are isomers.

Compound **E** reacts with sodium hydroxide in a 1:1 molar ratio.

0.412 g of compound **E** in aqueous solution requires 23.40 cm<sup>3</sup> of sodium hydroxide solution of concentration 0.200 mol dm<sup>-3</sup> for complete neutralisation.





- (i) Calculate the relative molecular mass of compound **E**.

[2]

Examiner  
only

Relative molecular mass = .....

- (ii) Identify compounds **A-E** giving your reasoning.

[7]

.....

.....

.....

.....

.....

.....

.....

.....

.....

.....

.....

.....

.....

.....

.....

.....

.....

.....

.....

.....

.....

.....

.....

.....

- (iii) Name the type of reaction taking place when compound **B** is converted back to compound **A**.

[1]

.....

- (b) Geraniol is one of the main constituents of rose oil and is widely used in perfumes and flavourings. Its structure is shown below.

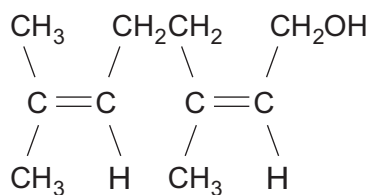

- (i) Name the functional groups present in the compound. [1]

.....

.....

- (ii) State the **molecular** formula of the compound. [1]

.....

- (iii) Draw the structure of an organic product formed when geraniol reacts with  
I. Br<sub>2</sub> [1]

- II. CH<sub>3</sub>COOH in the presence of sulfuric acid [1]

Examiner  
only



**BLANK PAGE**

9. Pentan-2-ol,  $\text{CH}_3\text{CH}_2\text{CH}_2\text{CH}(\text{OH})\text{CH}_3$ , is one of the isomers of  $\text{C}_5\text{H}_{11}\text{OH}$ . It has a relative molecular mass of 88.1.

A student carried out an experiment on a sample of pentan-2-ol to determine its enthalpy of combustion using the apparatus shown below.

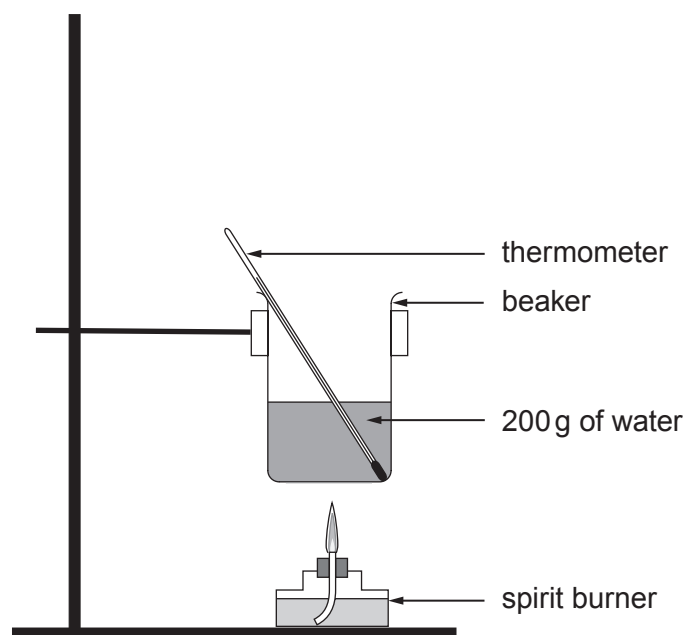

The spirit burner was lit and allowed to burn for a few minutes before it was extinguished.

The following results were recorded.

Initial temperature of the water	18.6 °C
Final temperature of the water	25.4 °C
Initial mass of spirit burner and pentan-2-ol	97.60 g
Final mass of spirit burner and pentan-2-ol	97.42 g

- (a) Calculate a value for the enthalpy change of combustion of pentan-2-ol in  $\text{kJ mol}^{-1}$ . [4]

Examiner  
only

$$\Delta_c H = \dots\dots\dots \text{kJ mol}^{-1}$$

- (b) (i) Each reading on the thermometer is accurate to  $\pm 0.1^\circ\text{C}$ . Calculate the percentage error in the temperature **difference** recorded. [1]

$$\text{Percentage error} = \dots\dots\dots \%$$

- (ii) Suggest how, using the same apparatus, the experiment could be improved to **reduce this percentage error**. Explain your answer. [2]

.....

.....

.....

.....

- (c) (i) Suggest an experimental improvement that would reduce error due to heat loss. [1]

.....

.....

- (ii) Suggest **one** reason, other than heat loss, why the value obtained for the enthalpy change of combustion is smaller than the theoretical value. [1]

.....

.....

- (d) Another isomer of  $C_5H_{11}OH$  is 2-methylbutan-2-ol,  $(CH_3)_2C(OH)CH_2CH_3$ . Standard enthalpy changes of combustion,  $\Delta_c H^\theta$ , can be found using standard enthalpy changes of formation,  $\Delta_f H^\theta$ .

The table shows some standard enthalpy changes of formation.

Substance	$\Delta_f H^\theta / \text{kJ mol}^{-1}$
$(CH_3)_2C(OH)CH_2CH_3(l)$	-380
$O_2(g)$	0
$CO_2(g)$	-394
$H_2O(l)$	-286

- (i) Write an equation for the complete combustion of  $C_5H_{11}OH$ . [1]

- (ii) Use the values in the table and the equation in part (i) to calculate the standard enthalpy change of combustion,  $\Delta_c H^\theta$ , of 2-methylbutan-2-ol. [2]

$$\Delta_c H^\theta = \dots\dots\dots \text{kJ mol}^{-1}$$

- (iii) State why  $O_2(g)$  has a value of zero for its standard enthalpy change of formation,  $\Delta_f H^\theta$ . [1]

- (e) A student was given separate samples of pentan-2-ol and 2-methylbutan-2-ol but was not told which was which.

Describe a chemical test that the student could use to clearly distinguish between the alcohols. Give any reagent(s) used and expected observation(s) for both compounds. [3]

.....

.....

.....

.....

.....

.....

- (f) Another student wanted to make pure 2-chloro-2-methylbutane from 2-methylbutan-2-ol in a multi-step process. One of the steps used was distillation.

- (i) An incomplete diagram of the distillation apparatus is shown below.

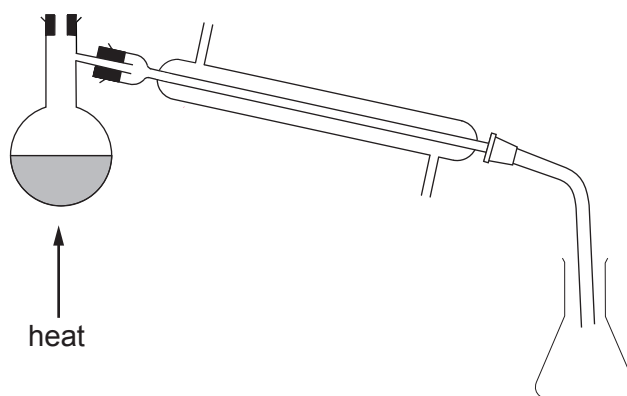

**Complete the diagram** by drawing a thermometer and clearly labelled arrows to show the flow of water into and out of the condenser. [2]

- (ii) The student predicted that since this was a multi-step process the overall yield would be less than 70%.

In the process, 5.00 cm<sup>3</sup> of 2-methylbutan-2-ol were used and 4.05 cm<sup>3</sup> of 2-chloro-2-methylbutane were made.

Is the student correct? Use the following information to justify your answer.

[3]

Compound	Density / g cm <sup>-3</sup>
2-methylbutan-2-ol	0.805
2-chloro-2-methylbutane	0.866

$$\text{density} = \frac{\text{mass}}{\text{volume}}$$

.....

.....

.....

Examiner  
only



**BLANK PAGE**

10. Hydrogen peroxide reacts with iodide ions in acid solution to produce iodine. The equation for the reaction is as follows.

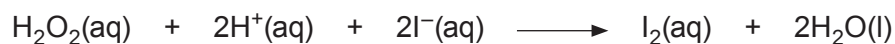

A student is asked to investigate the effect of changing the concentration of hydrogen peroxide on the rate of reaction by a "clock method".

She is told to carry out the following method.

- Measure 10.0 cm<sup>3</sup> of sulfuric acid, 10.0 cm<sup>3</sup> of sodium thiosulfate, 15.0 cm<sup>3</sup> of potassium iodide and 1.0 cm<sup>3</sup> of starch solution into a conical flask.
- Measure 5.0 cm<sup>3</sup> of hydrogen peroxide and 9.0 cm<sup>3</sup> of water into a boiling tube.
- Add the peroxide solution to the other reagents in the flask and start a stopwatch at the same time.
- Record the time taken, to the nearest second, for a blue-black colour to form in the reaction mixture.
- Repeat the procedure five times, with each run differing only in the peroxide concentration in the mixture, ensuring that the reaction times are neither too short nor too long.

She obtains the following results.

Experiment	Volume H <sub>2</sub> O <sub>2</sub> / cm <sup>3</sup>	Volume H <sub>2</sub> O / cm <sup>3</sup>	Time / s	$\frac{1}{\text{Time}} / \text{s}^{-1}$
1	5.0	9.0	28	0.0357
2	6.0	8.0		
3	7.0	7.0	17	0.0589
4	4.0	10.0	36	0.0278
5	3.0	11.0	54	0.0185
6	2.0	12.0	102	0.0098

- (a) The student says that it would be better to make up a single batch containing the acid, thiosulfate, iodide and starch solutions in the correct proportions before starting and use  $36.0\text{ cm}^3$  of this in each experiment. Is she correct? Justify your answer. [1]

.....

.....

.....

- (b) State **two** changes which could be made in order to improve the results in this experiment. Explain your reason in each case. [4]

.....

.....

.....

.....

.....

- (c) Give a reason why the peroxide is measured into a boiling tube first and not added directly to the flask from a burette. [1]

.....

.....

- (d) Suggest a reason why the student did not carry out the procedure using  $8.0\text{ cm}^3$  of hydrogen peroxide and  $6.0\text{ cm}^3$  of water. [1]

.....

.....

(e) She plotted a graph of rate against concentration of peroxide. This is shown below.

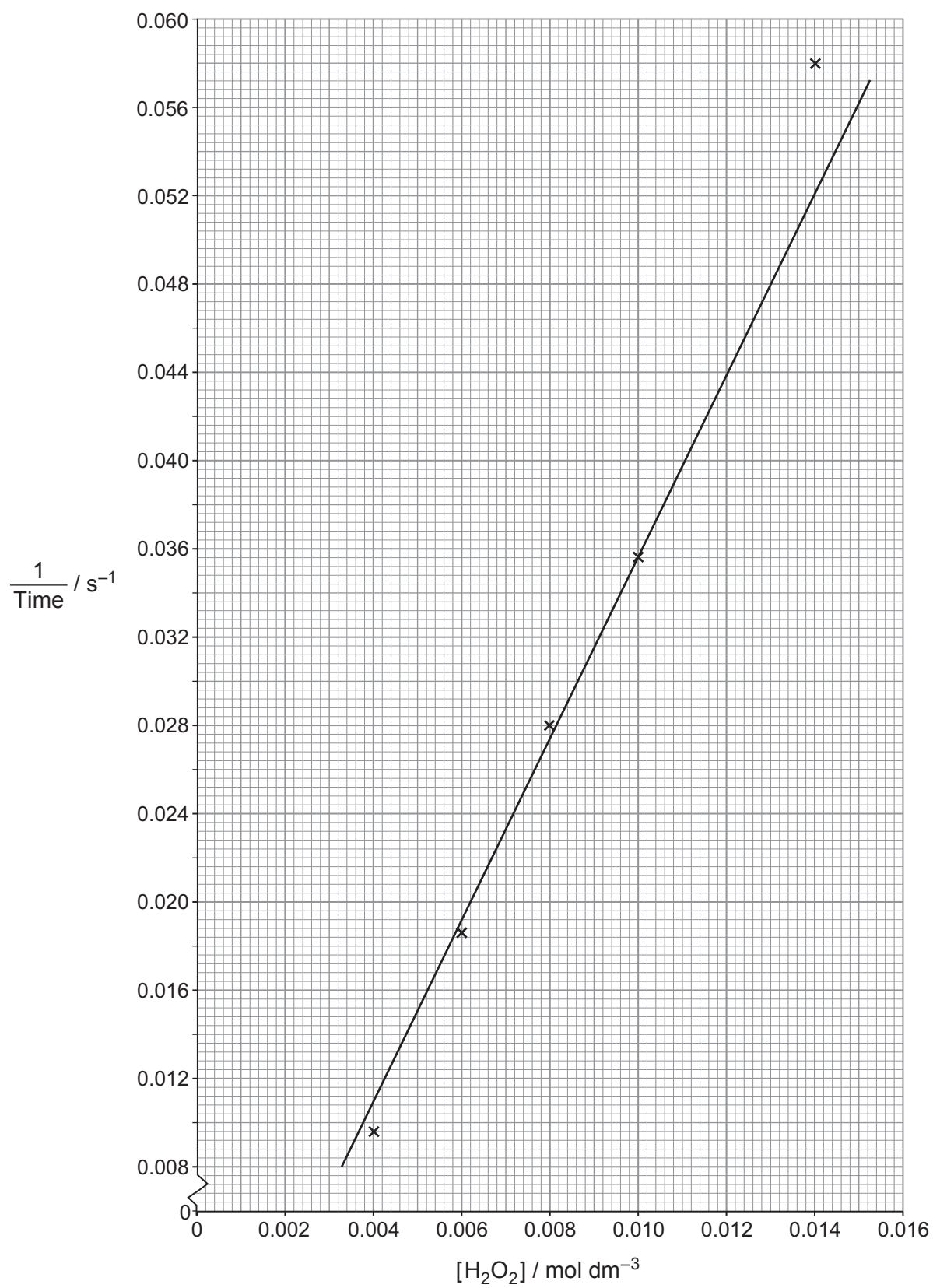

- (i) State how the rate depends on the concentration of peroxide. [1]

.....

.....

- (ii) Use the graph to find the time taken for the colour change to occur when she used  $6.0\text{ cm}^3$  of hydrogen peroxide and  $8.0\text{ cm}^3$  of water. [2]

Time = ..... s

- (f) Suggest another method, not using sodium thiosulfate, by which the rate of this oxidation reaction could be measured. [2]

.....

.....

.....

- (g) Explain, using simple collision theory, why the rate of this reaction changes as the concentration of hydrogen peroxide changes. [2]

.....

.....

.....

.....

Examiner  
only

14

**END OF PAPER**



**BLANK PAGE**